

## Modification of USB Sound Card for Asterisk app\_rpt Use

First off a huge thank you to Steve for providing the original notes on how to modify a USB sound card. (<http://images.qrvc.com/usbfob.pdf>) These instructions were invaluable when it came time for me to bring my first AllStar node on line. Feel free to email me for questions, errors or comments about this document: ka6oij @ arrl.net

What follows is my experience with modification of a USB sound card. The actual chip on this board was a CM-119 chip. The other options chips that will work are a CM108, CM108AH or CM109 Chip.

I took a chance when buying these as the exact chip set was not known. They are cheap enough that you can buy a few until you find one with the correct guts

This is what the guts look like before any modification and what the final modify product looks like.

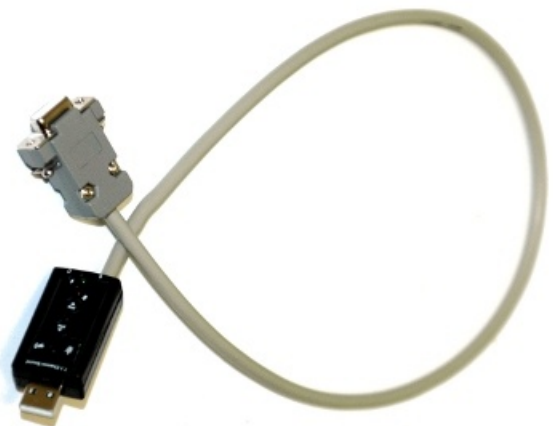
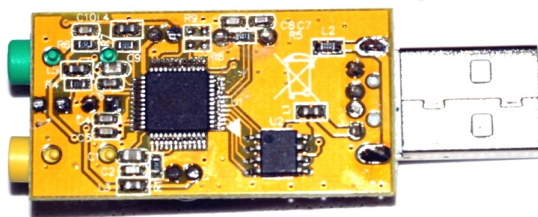

### Required parts:

1. USB sound fob
2. 10k ohm 1/8 W or 1/4 W through hole resistor
3. 68k ohm 1/8 W or 1/4 W through hole resistor
4. 470k ohm 1/8 W or 1/4 W through hole resistor
5. 10 µf 25V non-polarized electrolytic cap
6. BAT43 or equivalent Schottky diode in DO-35 package
7. 2N4401 NPN bipolar transistor in TO-92 package
8. Wire wrap wire or equivalent tiny wire
9. Plastic sleeving and heat shrink tubing
10. Hot melt glue and glue gun
11. Super-glue
12. Female D-sub connector and hood
13. 18 inch of 5 conductor shielded cabled with 28awg stranded wire or smaller
14. Temperature controlled Soldering iron
15. Precision cutters and long nose pliers
16. X-acto knife

My part list is virtually the same as the original instructions. The actual parts I used were based on what I had in my junk drawers as the actual parts are not that critical but I list the original parts as they

are a good starting point. You can use your favorite NPN switching transistor assuming it has a Beta high enough to switch fast enough and can handle the current of your radio (2N3904, 2N2222, etc).

The diode is not critical though using a Schottky diode is suggested due the fast switch rate and low voltage drop they have.

I found that basic audio output circuit on most USB key fob to easily pass the low frequencies needed for the PL tone. Just do a quick look at the two audio output capacitors and verify that they are larger than around  $4.7\mu\text{f}$ . I had 3 different batches of boards with 2 different output capacitors values. In most cases the capacitors were  $100\mu\text{f}$  but in one batch of boards they were miniature 70pf chip capacitors. Digikey part P963-ND  $100\mu\text{f}$  capacitor worked well as a replacement capacitor in this case and could be easily soldered into place. The positive side of the capacitors should be solder to the trace connecting to the IC.

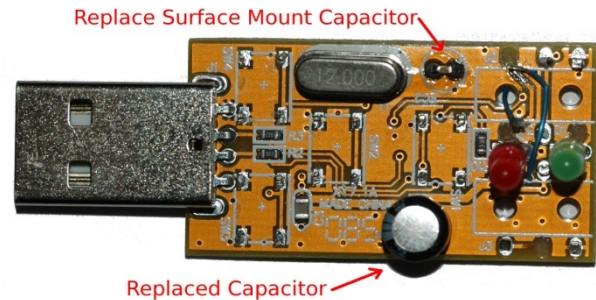

The audio input circuit on the boards do have a bit of an audio cut off and hence I choose to follow Steve's original design and replace it. The actual size of the capacitor to use is not all that critical as the aim is simply to have a value large enough to pass the PL frequencies so anything in the  $4.7\mu\text{f}$ - $100\mu\text{f}$  should be fine.

### **Step 1 -- Open the Key Fob and Glue In the Switches**

The first step is to carefully open the USB key fob. Most of the key fobs are held together with nothing more than friction. Take a small screwdriver and carefully pry the two sides of the clam shell apart.

Once apart remove the circuit board and set aside. Remove the 2 plastic pieces in the front cover that is used to push the buttons down and use a bit of super glue to glue in the switches. Once the glue is dry use the cutters to cut the plastic pieces off.

Now grab the circuit board and inspect it. Solder the USB plug if it is not soldered.

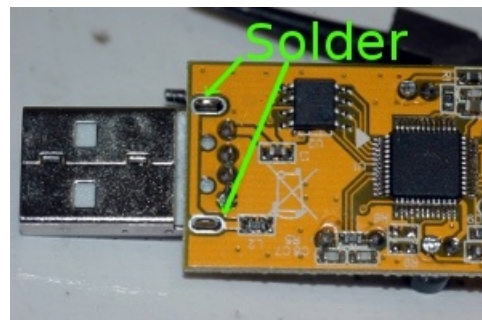

## Step 2 -- Removed of Unneeded Components

It is time to remove all the hardware we are not going to need. This includes both jacks and all 4 push buttons. Depending upon my mood I will either completely remove the push buttons or just break off the tops to expose the leads underneath. When removing components do not try to de-solder them but instead use sharp cutters and cut off the leads. Even if you choose to leave the other push buttons it is still much easier to completely remove the switch where the PTT transistor will go.

Be careful when removing the jacks as it is very easy to pull traces up from the board as shown in the photo at the right. It is much easier to cut the leads than to try to unsolder them. In the event you tear the board up the first step is to fix the boo-boo. I found that wire wrap wire worked very well for the job.

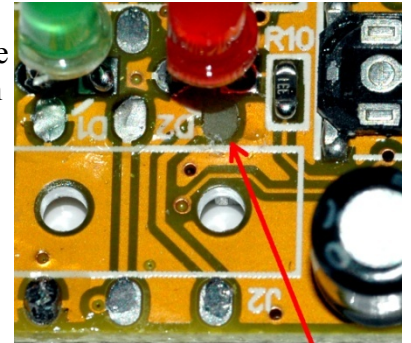

Torn Pad

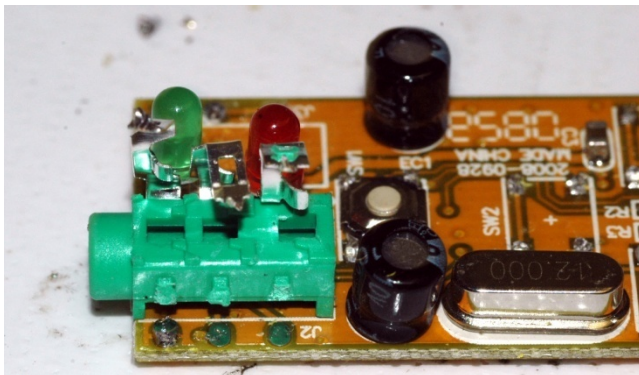

The method I found that worked without destroying the trace when remove the 2 jacks was to first cut the 3 pins on the outside. Then carefully pry up the pins around the outside of the plastic jack with a small screwdriver and remove the plastic piece. Once removed cut the 3 pins.

In the event you do make a mistake and remove a hunk of the circuit board use wire wrap wire to fix it.

My most common boo-boo was fixed by first taking an X-acto knife to expose the circuit board as shown and then soldering a wire to the board and feeding it through the one of the holes before soldering the other end of the wire.

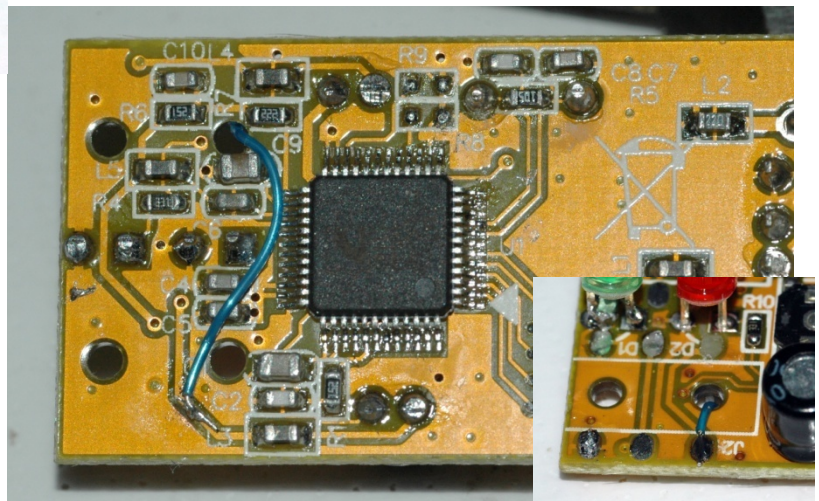



### Step 3 -- Delicate Soldering (TX Audio/Transistor)

Before soldering verify that your board is like the one pictured at the right. For the receive audio we will remove the board's existing audio circuit and make a direct connection to pin 27 of the CM108/119/109.

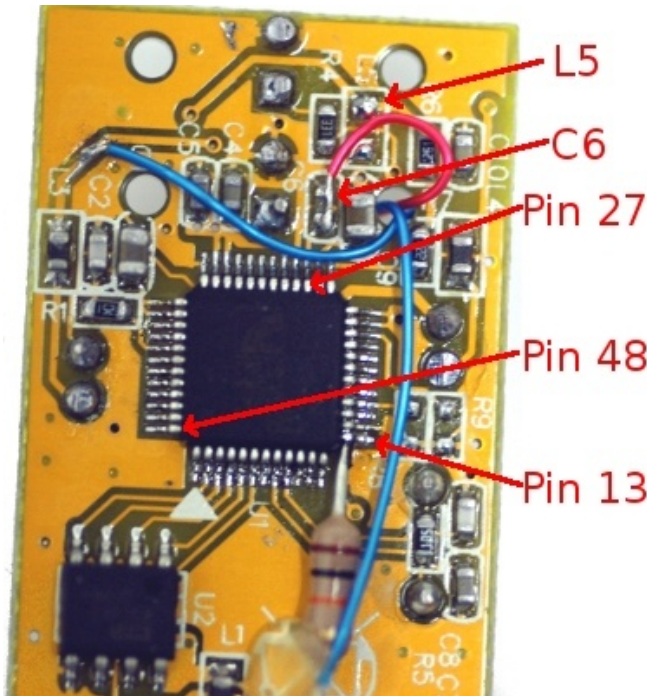

After verifying that L5 is directly connected to C6 and that C6 is connected to pin 26, remove L5 by gently heating one side up and then the other and pushing it aside with the iron. Then solder a wire directly to the top of C6. Don't be tempted to just remove C6 and try to solder directly to the pad as the pads are very fragile and is it far easier to just bridge the top of C6. The other end of the wire should be routed through the hole with about ½ inch sticking through.

Take a 10K ohm resistor and cut and bend it to size. Tin the ends so that the final soldering will be easier and take a dab of hot glue and position it in place against pin 13. Once the hot glue sets then heat the joint and solder it in place. Apply a wire to the resistor and route through the hole and to back to the far end of the board.

Take your favorite NPN switching transistor and solder the emitter to the ground plan. Then take a dab of hot glue to hold the transistor in place. Attach the wire from the 10K ohm resistor to the base.

Now attach the diode to pin 48. The easiest place to solder to is on the switch as shown. If you removed the entire switch then the lower right hand pad will be the direct connection to Pin 48. Use a volt meter to verify the exact pad.

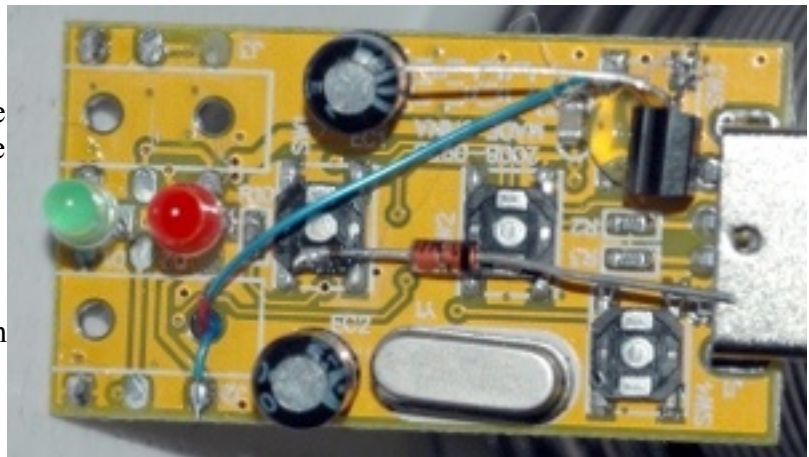

2N4401

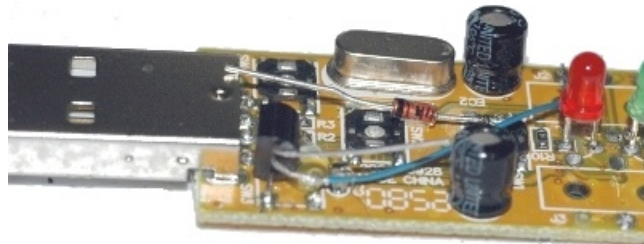
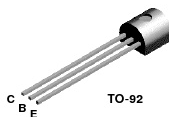

## Step 4 – Last components

Solder the capacitor to the wire going to the Audio input. If you have a radial lead capacitor it can just be soldered in place otherwise it seems to work to bend one of the capacitor leads around. A dab of hot glue works well to keep it in place. Keep in mind that the capacitor has to be kept low to the board so that the plastic clam shell can go back on.

Use an X-acto knife to scrap down to the ground plane--or just solder to the ground lead if you removed the switch. Solder the 68K ohm resistor to the ground plane. Finally solder in the 470K ohm resistor.



## Step 5 – Cable

On the back side of the board scrap down to the ground plane and solder the cable to the key fob so as to get a reasonable good mechanical connection. You could also use some of the unused wires to thread in and out of the two holes if you wish to have a more sturdy connection.

Attach the wires:

- Green wire (COR) to the diode--a bit of heat shrink might be necessary to avoid a short
- Red wire (PTT) to the collector of the transistor.
- Gray wire (RX Audio) to the 470K ohm resistor
- Brown wire (AuxAudio) to the end pad where the earphone jack use to be
- Black wire (TX Audio) to the middle pad where the earphone jack use to be

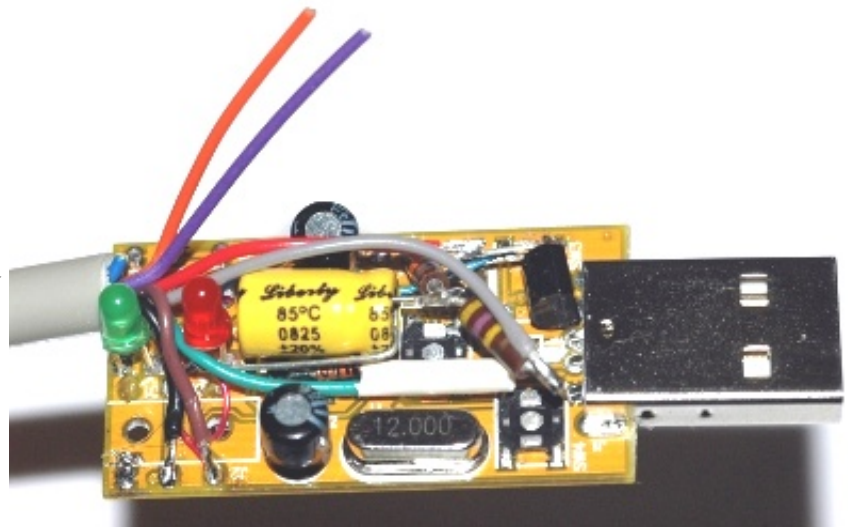

I chose to build my DB9 connectors to be compatible with an RLC controller. This makes it very easy to remove the existing controller and replace it with the modern controller.

For most applications the AuxAudio (brown wire) will also need to be brought through the connector as most legacy controllers don't support CTCSS and any tone boards currently in place should be removed. I use non-standard pin 2 for that function.

Pin	Function	Color
1	Gnd	Shield
2	AuxAudio	Brown
3	PTT	Red
4	TX Audio	Black
5	RX Audio	Gray
6	Gnd	Shield
7	COR	Green
8	Gnd	Shield
9	N/C	



Final Circuit:

